



# DB/DBW...L5X 型

## DBT 型

(NG) 10 32  
350bar  
650L/min

### 目录

### 特点

- 
- DIN24340E ISO 6264
- 
- 5
- 
- 4
- 
- 
- 
- 
- ( DBW )

DB DBW

(3)

(1)

(DB)

(DBW)

(2)

(DB)

**DB 型溢流**

带切换时间<sup>1)</sup>

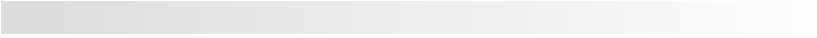

03

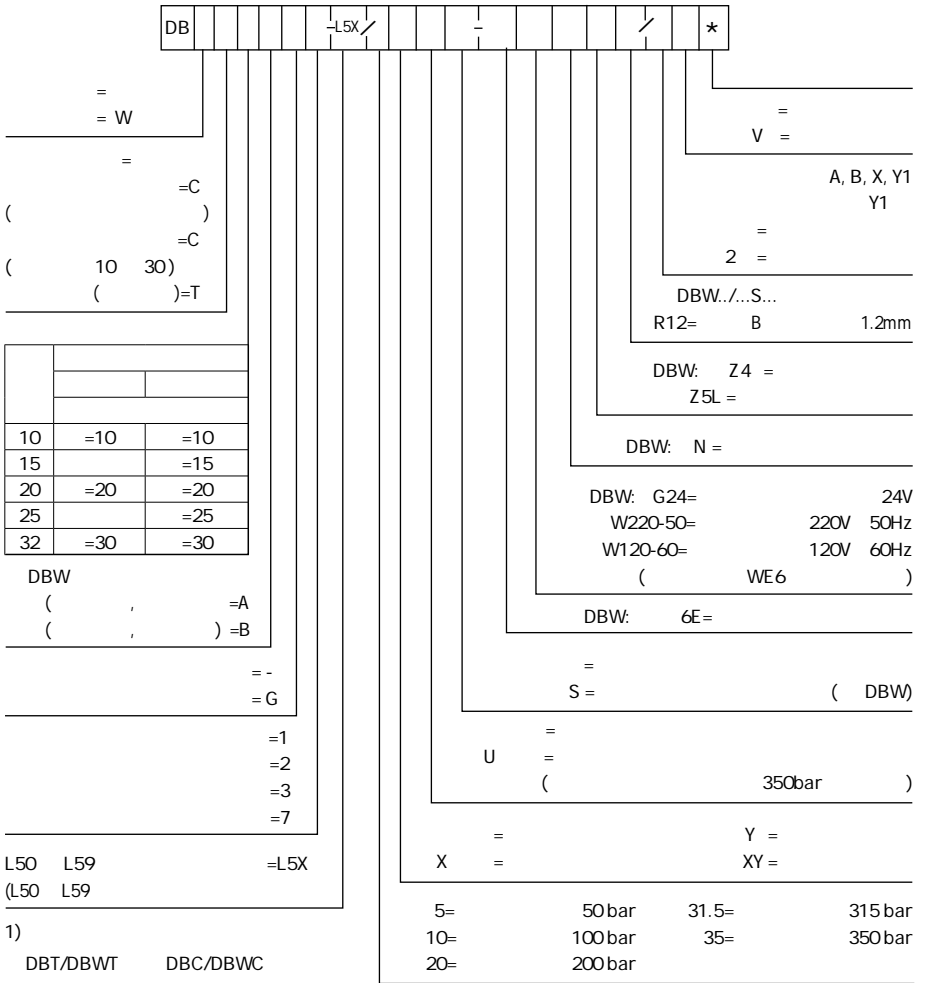

03

1

DBD

DBD

2 " U"

( HLP46  $\varnothing = 40 \pm 5$  )

B

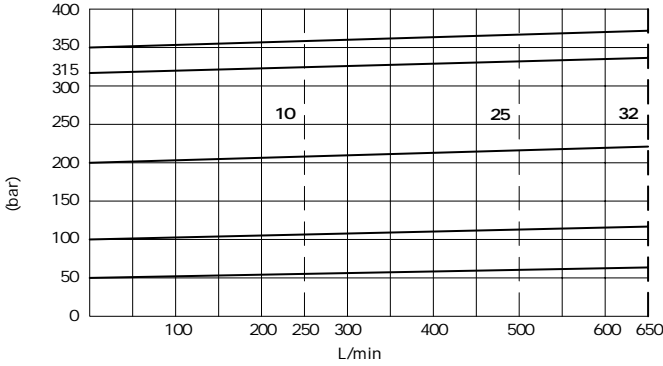

!

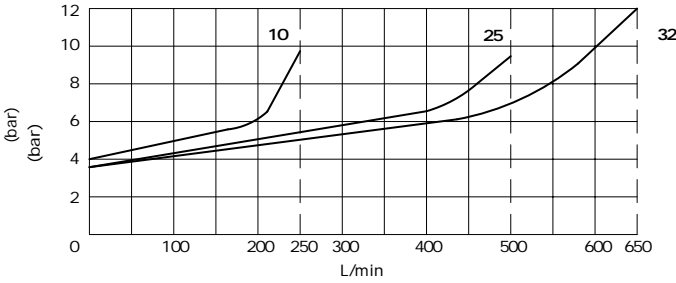

!

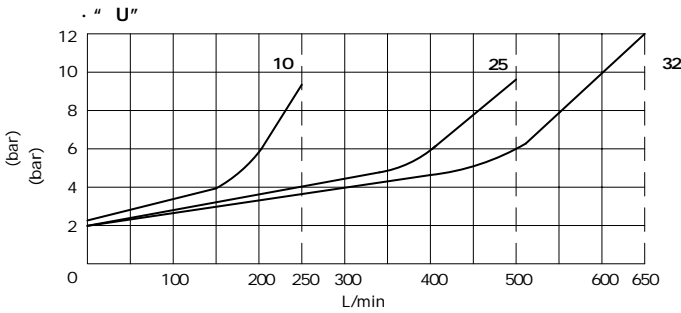



(            mm)

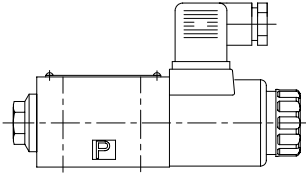

03

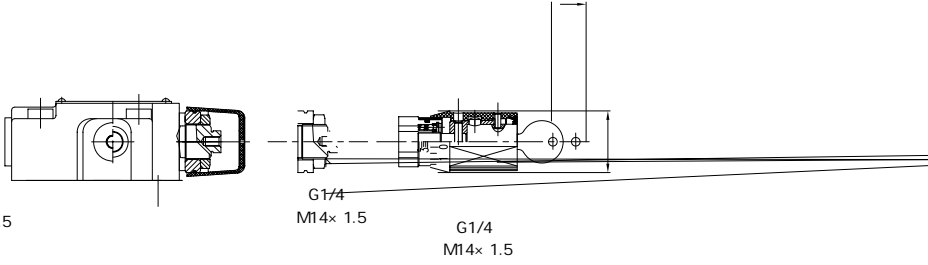

G1/4  
M14× 1.5

G1/4  
M14× 1.5

G1/4  
M14× 1.5

**DB..G..L5X**

**DB..G..30**







## DB/DBW52...L3X 型

52

315 bar

2000L/min

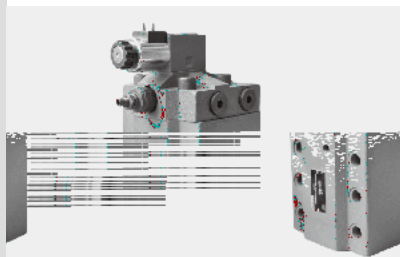

### 目录

### 特点

- 
- 
- 2
- 4
- 
- 
-

03

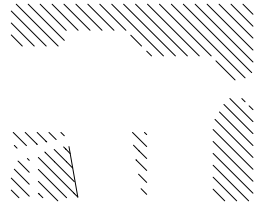



	DB52...	kg	27.6	
	DBW52...6E	kg	29.5	
			WE6	4WE6D9      4WE6Y9
			-	
			-	
			-30	+80
			-20	+80 (      )
			-20	+80
			mm <sup>2</sup> /s	
			NAS1638 9      ISO4406 20/18/15	
03	P, T, X	bar	315	
	Y	DB 52...	315	
		DBW52...6E	210	160
	Max.	bar	315	
	Min.	bar	(      )	
			L/min	2000

(      HLP46  $\varnothing$  =40  $\pm$  5      )

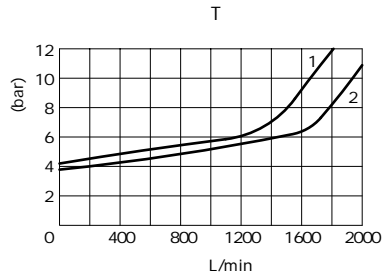
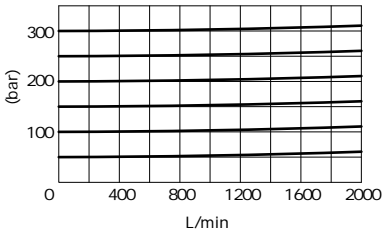

- 1 -
- 2 -

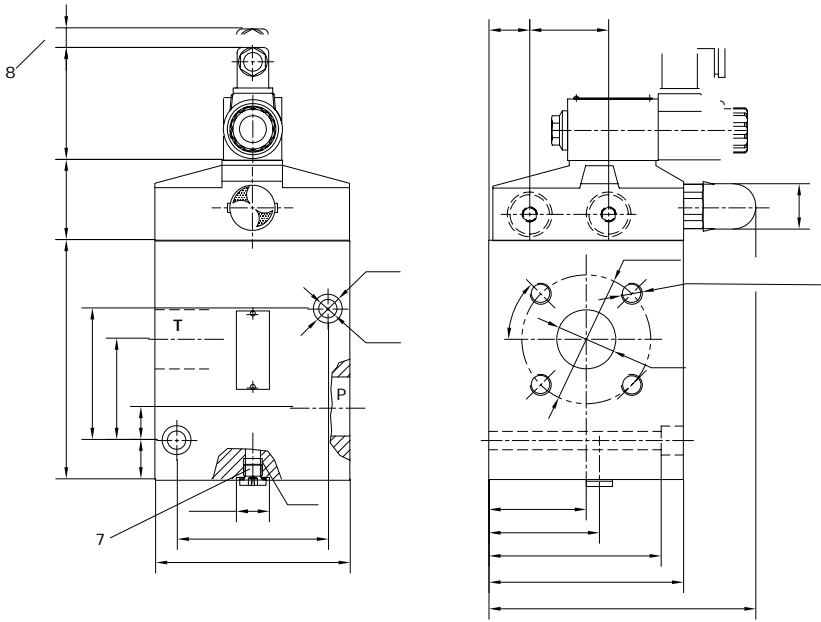

03

