



6.19

Proportional amplifier

Type VT 2000

For controlling proportional pressure valve.
EURO circuit board structure.



Contents

Technical data	02
Ordering code	02
Characteristic curve	02
Wiring diagram of amplifier: VT-2000BS40G	03
Application specification: VT-2000BS40G	04
Outline dimension: VT-2000BS40G	05
Wiring diagram of amplifier: VT-2000BK40	06
Application specification: VT-2000BK40	07
Outline dimension: VT-2000BK40	08

Features

- VT-2000 is a proportional power amplifier and consists of:
- Voltage regulator
 - Two input circuits of differential and potentiometer
 - Controllable constant current generator
 - Ramp generator
 - Oscillator 200Hz
 - Ramp adjustable for time of "up" and "down"

Technical data

Weight	m	Approx. 0.15kg
Voltage	U	DC 24V (-5% ~+10%)
Power	P	30VA
Fuse wire	Is	1.2AT
Control voltage	U	Input differential 0~+10V Manual potentiometer input 0~+9V
Mn. load resistance for control voltage	R	500
Max. output current	I_{max}	800mA
Max. load resistance	R	30
Pilot current	I	100mA
Vibration current frequency	f	200Hz
Ambient temperature	t	0~40
Temperature drift		0.5‰(max. current value)/

Ordering code

VT-2000		40		*	
Bare terminal	=BK				Further details in clear text
32 ends plug to DIN41612 (For EURO circuit board breadth)	=BS			G=	second generation (only for BS version)
		40=			Series 40

Characteristic curve

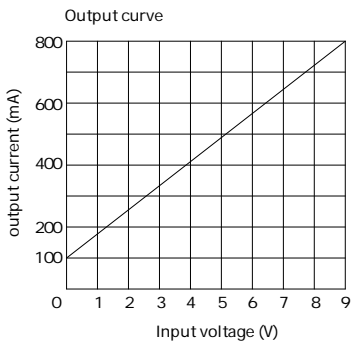

Wiring diagram of amplifier

Type VT-2000BS40G

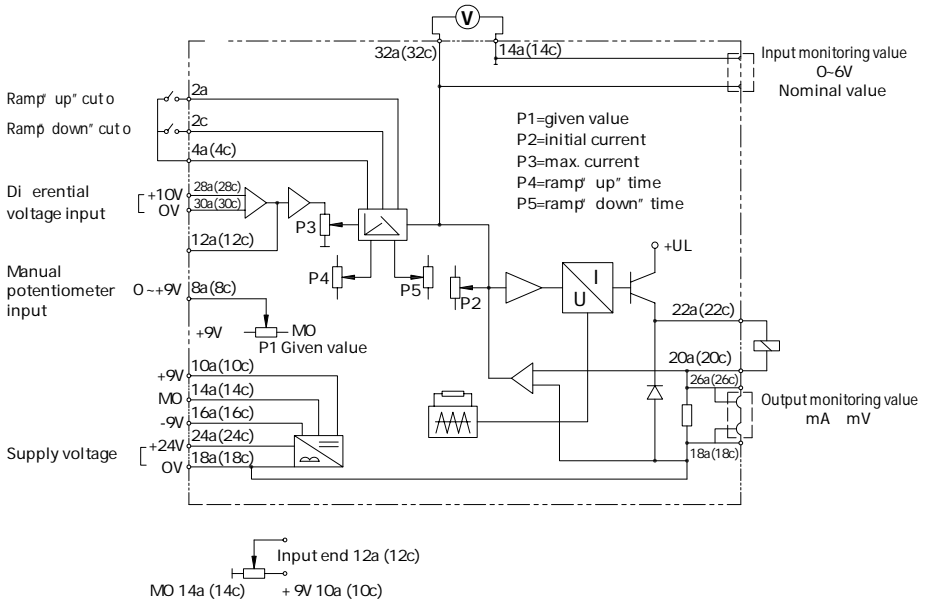

Application specification

Principle chart of Hydro-electric proportional amplifier type VT-2000BS40G see Wiring Chart

1. 20a (20c), 22a (22c) in the right of the dotted line, connects with proportional solenoid coil, And 22a (22c) is the high electric potential and 20a(20c) is the low electric potential.
2. 24a (24c), 18a (18c, 16a, 16c) in the left of the dotted line, connects with DC 24V power, among them, 24a (24c) connects the positive pole, 18a (18c, 16a, 16c) connects the negative pole. The controller's power shall be separate with the differential input power, namely 30a (30c) can't connect the 14a (14c) and 18a (18c, 16a, 16c), otherwise, it could be damage the controller.
3. Two controlling methods:
 - (1). manual control:
 - a: External potentiometer (provided by user themselves, suggesting to use one with resistance greater than 5K and smaller than 10K but smaller than 2K is not permitted; Power is not limited), one end connects 10a (10c) (+9), another end connects 14a (14c) (MO is the measurement zero); and the slide end connects 12a (12c). Input the voltage value 0- +9V into 12a (12c) end by adjusting the potentiometer, and 100-800mA square wave pulse current will proportionally appears from the proportional solenoid.
 - b: The controller has a built-in input potentiometer P1, the amplifier panel <given value> potentiometer, which can replace of external potentiometer. When using P1, put through 8a (8c) and 12a (12c), then it can get 100-800mA current from the solenoid to control the solenoid outputting force.
 - (2). Automatic control:

Differential voltage signal from the programmable controller (PLC), function generator and so on inputs from 28a (28c), 30a (30c), and 28a (28c) connects high frequency, while 30a (30c) low frequency. Correspondingly appearing 100-800mA in the solenoid when the differential changes at range of 0-10V. Notes: Don't make the 30a (30c) connected with the 14a (14c)(MO) or negative end 18a (18c), 16a (16c) of the DC24V power, namely the PLC and the proportional controller can't use one power or have mutual grounding.

When the requiring current is less than 800mA, it can limit the max. current by adjusting the P3 in the amplifier panel, e.g. input +9V to end 12, it can limit the output current 800mA into 600mA or other values by adjusting the potentiometer P3.

Two potentiometer P4 and P5 in the amplifier panel is respectively used for adjusting the time of ramp "up" and "down", and the adjustable time range is 0.2-5 seconds.

There is two pairs test holes, the 0-+6V test hole for normal holes, for flow control and the 0-10V test hole for

Outline dimension

Type VT-2000BS40G

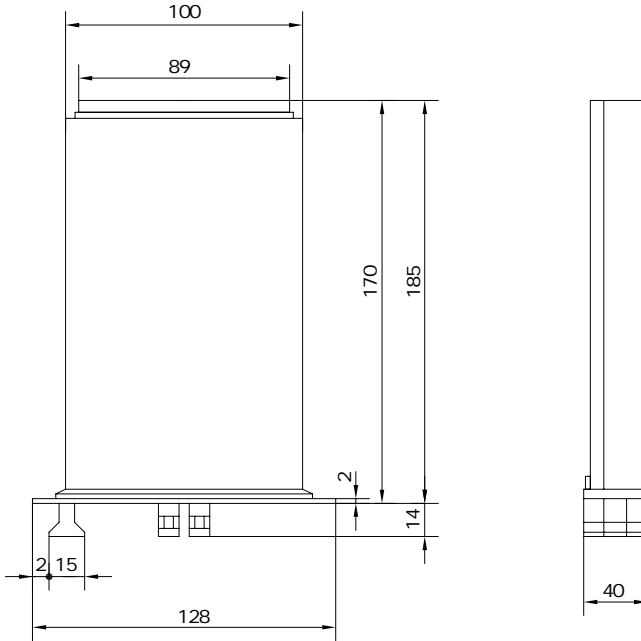

Amplifier type VT-2000BS40G circuit outline dimension adopts Europe standard 100× 160 mm, connector is Europe 32 ends plug, and it has a stand type VT-3002L forming a complete set.

Wiring diagram of amplifier

Type VT-2000BK40

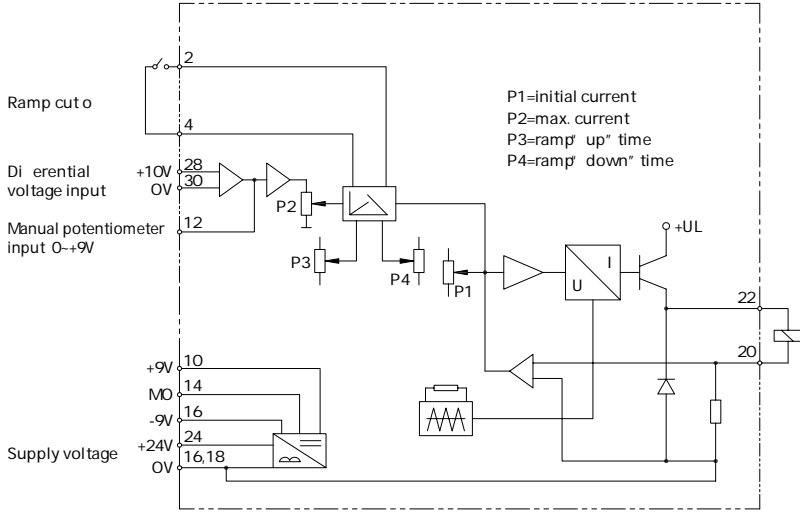

06

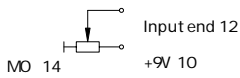

Application specification

Type VT-2000BK40

Principle chart of Hydro-electrical proportional amplifier type VT-2000BK40 see Wiring Chart.

1. End 20 and 22 in the right of the dotted line, connects with proportional solenoid coil (22 is the high electric potential and 20 is the low electric potential.)

2. End 24, 18 (or 16) in the left of the dotted line, connects with DC 24V power, among them, 24 connects the positive pole, 18 or 16 connects the negative pole. The controller's power shall be separate with the differential input power, namely end 30 can't connect the 14 and 18 or 16, otherwise, it could be damage the controller.

3. Two controlling methods:

(1) Manual control:

External potentiometer (provided by user themselves, suggesting to use one with resistance greater than 5K and smaller than 10K but smaller than 2K is not permitted; Power is not limited), one end connects 10 (+9), another end connects 14 (MO is the measurement zero); and the slide end connects 12. Input the voltage value 0~+9V into end 12 by adjusting the potentiometer, and 100~800 mA square wave pulse current will proportionally appear from the proportional solenoid to actuate it.

(2) Automatic control:

Differential voltage signal from the programmable controller (PLC), function generator and so on inputs from end 28 and 30, among them, end 28 connects high frequency, while 30 low frequency. Correspondingly appearing 100~800mA in the solenoid when the differential changes at range of 0~10V.

Notes: Don't make the end 30 connected with the 14 (MO) or negative end 18, 16 of the DC24V power, namely the PLC and the proportional controller can't use one power or have mutual grounding.

When the requiring current is less than 800mA, it can limit the max. current by adjusting the P2 in the amplifier panel, e.g. input +9V to end 12, it can limit the output current 800mA into 600mA or other values by adjusting the potentiometer P2.

Two potentiometer P3 and P4 in the amplifier panel is respectively used for adjusting the time of ramp "up" and "down", and the Max. time of ramp is 5 seconds. If system needn't ramp time, 2 and 4 can be short-circuited.

Potentiometer P1 on the panel is used for adjusting the pilot current with the range 0~400mA; and preset current is 100mA before dispatch from factory.

Note:

Other potentiometers on the panel have been adjusted before shipment from factory, if you modify it, the performance parameter given by the manual will not be assured.

Outline dimension

Type VT-2000BK40

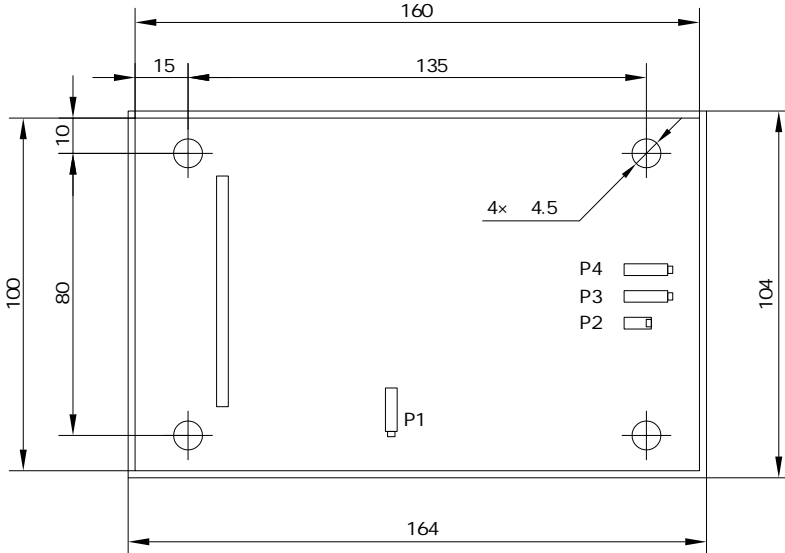

Amplifier type VT-2000BK40 circuit outline dimension adopts Europe standard 100× 160 mm, with plastics supporting board (1mm thick), the wiring terminal can connect the cable directly.